

DESCRIPTION

DO-214AA/SMB Thyristor solid state protection thyristor protect telecommunications equipment such as modems, line cards, fax machines, and other CPE. This Series devices are used to enable equipment to meet various regulatory requirements including GR1089, ITUK.20, K.21 and K.45, IEC 60950, and TIA-968 (formerly known as FCC Part 68).

FEATURE

- > Excellent capability of absorbing transient surge
- > Quick response to surge voltage
- > Eliminates overvoltage caused by fast rising transients
- > Solid-state silicon technology, non degenerative

APPLICATIONS

- > Audio/Video line
- > Network and telecom
- > Data lines and security systems
- > Serial ports

Symbol	Parameter	Value	Unit
T _J	Operating Junction Temperature	-55 to +150	°C
T _S	Storage Temperature Range	-55 to +150	°C
R _{θJA}	Junction to Ambient on printed circuit	90	°C/W

PART NUMBER	VDRM V Min.	IDRM uA Max.	VS V Max.	IS mA Max.	VT V Max.	IT A Max.	IH mA Min.	CO pF Typ.
P0060SC	6	5	15	800	4	2.2	40	80
P0080SC	6	5	25	800	4	2.2	40	80
P0150SC	15	5	25	800	4	2.2	40	80
P0300SC	25	5	40	800	4	2.2	40	80
P0640SC	58	5	77	800	4	2.2	120	60
P0720SC	65	5	88	800	4	2.2	120	60
P0900SC	75	5	98	800	4	2.2	120	55
P1100SC	90	5	130	800	4	2.2	120	55
P1300SC	120	5	160	800	4	2.2	120	55
P1500SC	140	5	180	800	4	2.2	120	60
P1800SC	170	5	220	800	4	2.2	120	60
P2300SC	190	5	260	800	4	2.2	120	55
P2600SC	220	5	300	800	4	2.2	120	50
P3100SC	275	5	350	800	4	2.2	120	50
P3500SC	320	5	400	800	4	2.2	120	40
P4200SC	400	5	520	800	4	2.2	≤50	40

- 1、Vs is measured at 100KV/S
- 2、Off-state capacitance is measured in VDC=2V, VRMS=1V, F=1MHz
- 3、All measurements are made at an ambient temperature of 25°C

SURGE RATINGS

PART NUMBER	VPP 10x700us (V)
P0060SB Thru P4200SC	6000

Series	IPP 2x10us (A)	IPP 8x20us (A)	IPP 10x560us (A)	IPP 10x1000us (A)	VPP 10x700us (V)	ITSM 60Hz (A)	di/dt (A/us)
P0060SC Thru P4200SC	500	400	100	80	6000	30	500

$dzW > s/ , Z d Z/^d/ ^$

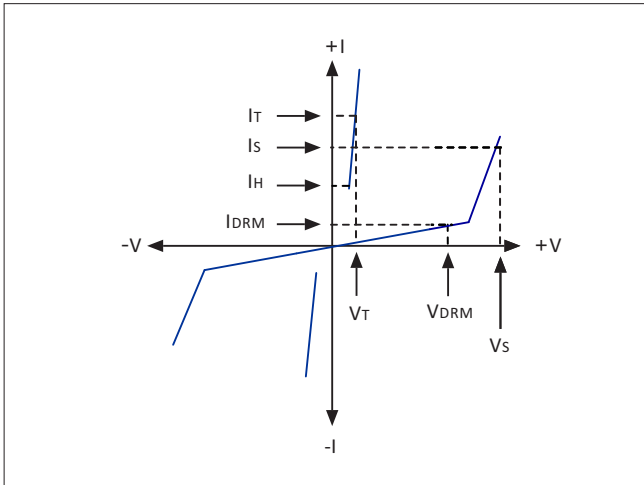

V-I Characteristics

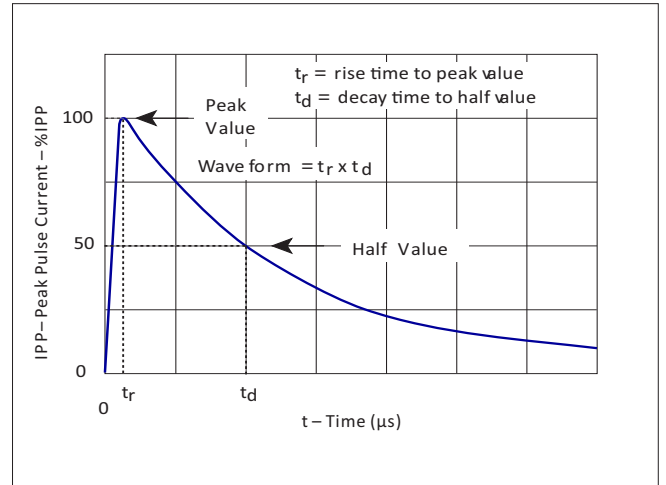

$t_r \times t_d$ Pulse Waveform

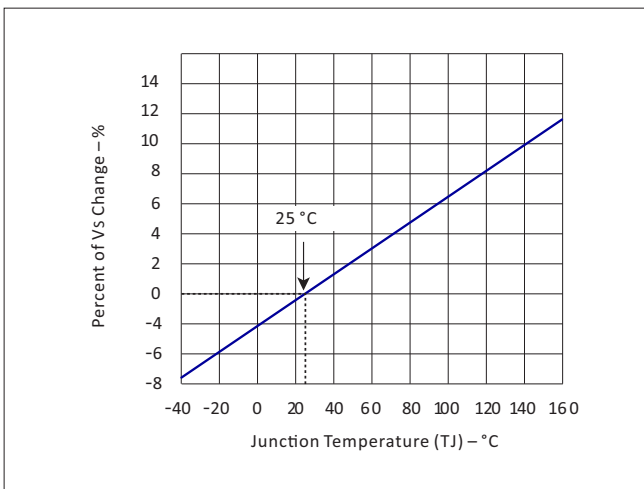

Normalized V_S Change vs. Junction Temperature

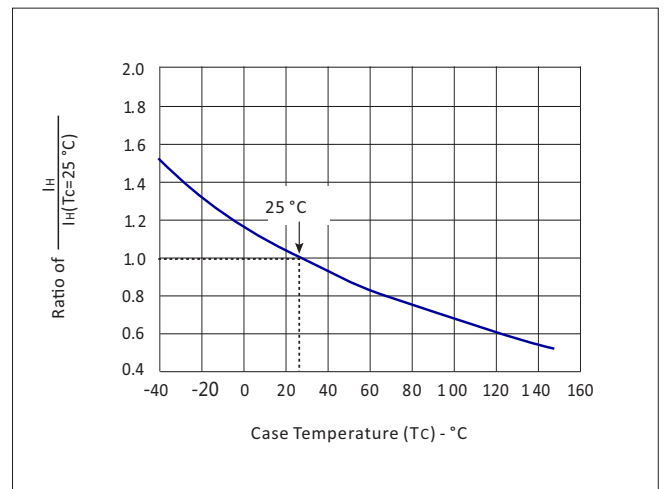

Normalized DC Holding Current vs. Case Temperature

^K> Z/E' WZ D d Z^

Reflow Condition		Lead-free assembly
Pre Heat	Temperature Min (Ts(min))	150°C
	Temperature Max (Ts(max))	200°C
	Time (min to max) (ts)	60 – 180 secs
Average ramp up rate (Liquidus Temp (TL) to peak)		3°C/second max
Ts(max)to TL - Ramp-up Rate		3°C/second max
Reflow	Temperature (TL) (Liquidus)	217°C
	Time (min to max) (tl)	60 – 150 seconds
Peak Temperature (TP)		260°C
Time within 5°C of actual peak Temperature (tp)		20 – 40 seconds
Ramp-down Rate		6°C/second max
Time 25°C to peak Temperature (TP)		8 minutes Max.
Do not exceed		260°C

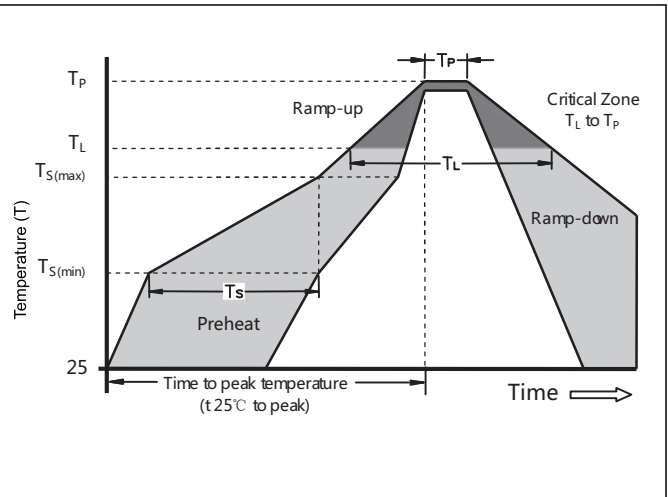

^D •W < ' /D E^/KE^

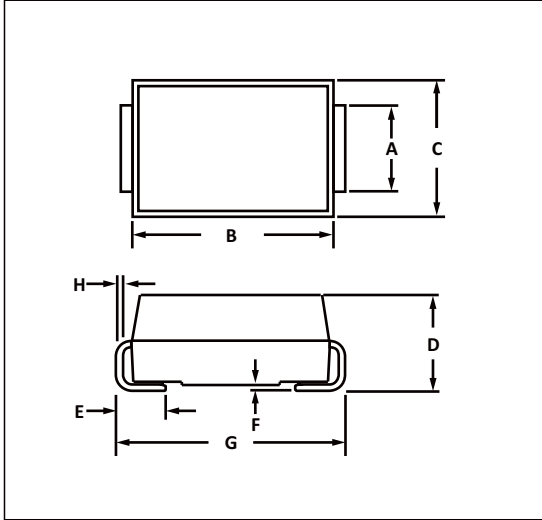

SMB PACKAGE DIMENSIONS				
DIM	MILLIMETERS		INCHES	
	MIN	MAX	MIN	MAX
A	1.96	2.20	0.077	0.087
B	4.35	4.85	0.171	0.191
C	3.30	3.94	0.130	0.155
D	2.20	2.50	0.087	0.098
E	0.76	1.52	0.030	0.060
F	0.02	0.20	0.001	0.008
G	5.08	5.59	0.200	0.220
H	0.15	0.30	0.006	0.012

NOTES:
 1. Dimensions are exclusive of mold flash and metal burrs

RECOMMENDED PAD LAYOUT DIMENSIONS

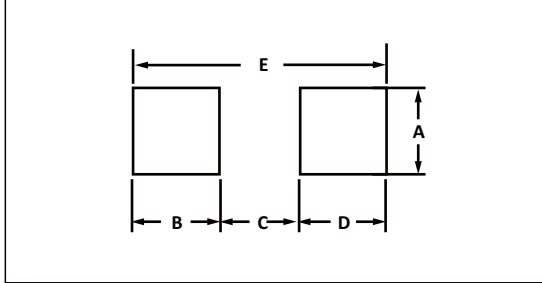

RECOMMENDED PAD LAYOUT DIMENSIONS				
DIM	MILLIMETERS		INCHES	
	MIN	MAX	MIN	MAX
A	2.20	-	0.087	-
B	1.45	-	0.057	-
C	-	2.55	-	0.100
D	1.45	-	0.057	-
E	5.60 REF		0.220 REF	

d W E Z >^W /& d/KE

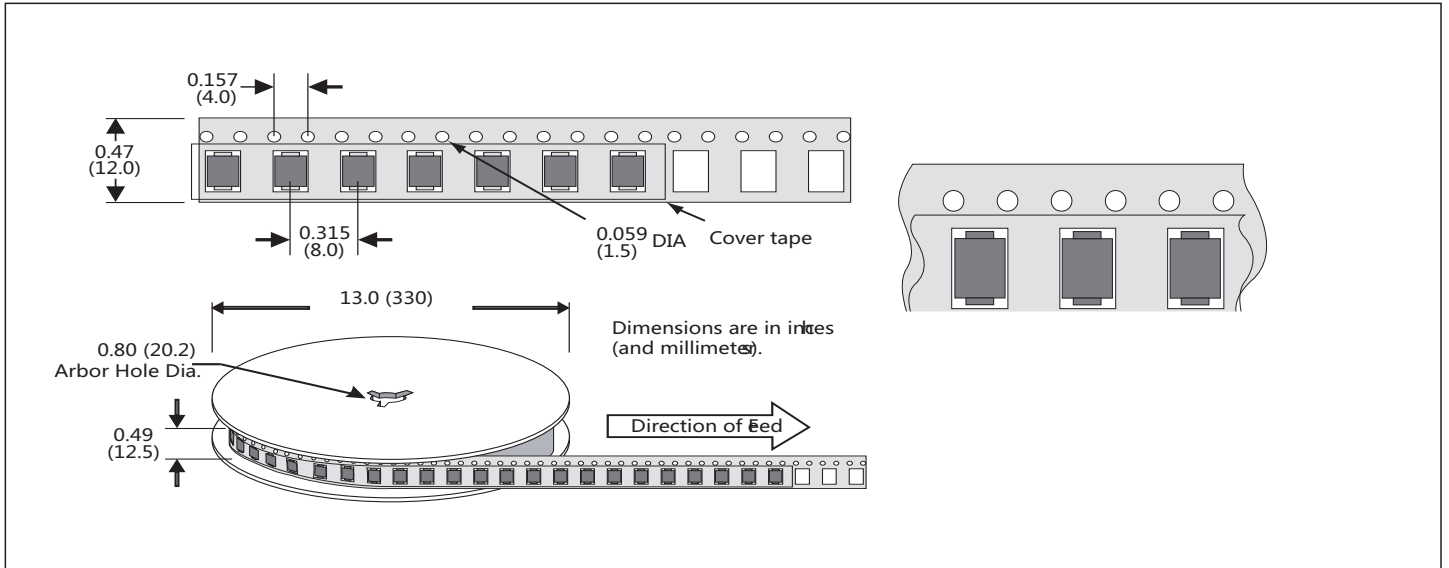

KZ Z/E' /E&KZD d/KE

Part Number	Component Package	QTY/Reel	Reel Size
PxxxxSC	DO-214AA(SMB)	3000PCS	13"